

2  1

B  

$\varnothing.4950^{+.003}_{-.003}$ A

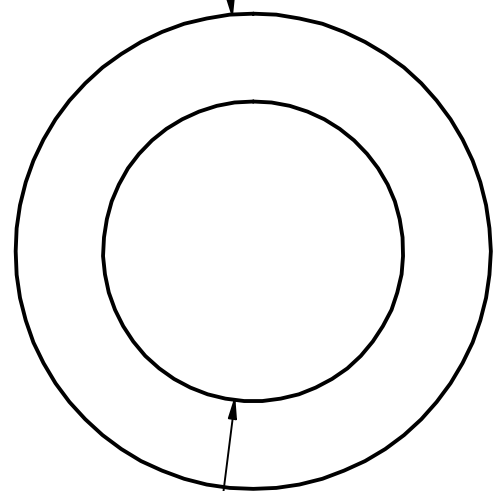

.1260 D

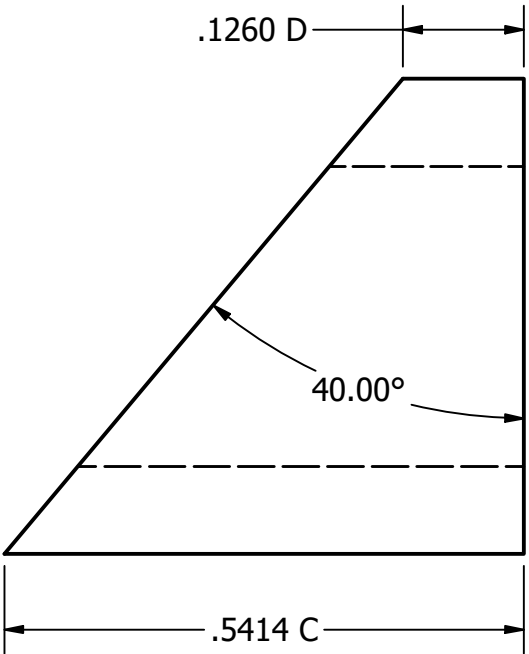

40.00°

.5414 C

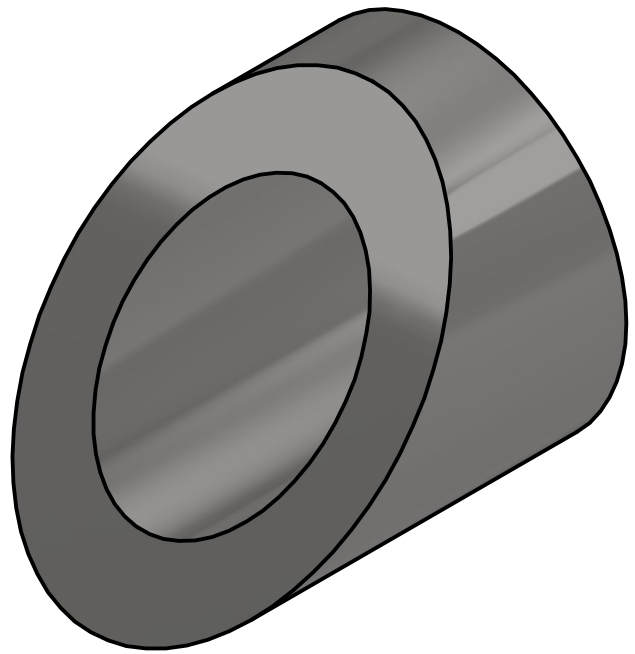

B 

$\varnothing.3125^{+.005}_{-.000}$ B

A

CRITICAL INSPECTION		
DIMENTION	TOLERANCE	DEVICE
A	+/- .003	CALIPER
B	+ .005/-0.0	CALIPER
C	+/- .003	CALIPER
D	+/- .003	CALIPER

A



PART #: 260945

PART NAME: 40 degree Rod Angled Washer.ipt



DRAWN BY: JJJ

DATE: 8/19/2018

STATUS: WorkInProgress

TOLERANCES
 .X = ± .030
 .XX = ± .015
 .XXX = ± .005

CYCLE TIME: N/A

MATERIAL 316SS

SIZE: A SCALE: 5 : 1

REV:

2



1